



ANCA

**ANCA**  
CNC MACHINES



# FX LINEAR

## THE LATEST TECHNOLOGY FOR FULL PRODUCTION

The FX Linear range is ideal for everything from light manufacturing, regrinding, and even full production. Its best performance and productivity range is for tools up to a diameter of 12mm (1/2"). It can also grind tools up to 200mm (7.8").

The machine range contains several features to make an operator's work easier. These include a touch screen customisable with Windows, a handheld pendant for easier set-up and an easy to access loader door for slide out pallets.

Every part on the machine, from the positioning of the grinding wheel on the C-axis centreline to reduce thermal influence, to the ANCA designed linear motors, have all been designed to enhance accuracy, increase productivity and make the operator's day easier.



### FX<sup>3</sup> LINEAR

An affordable first step into CNC tool grinding, or an economical, good quality basic machine. Whatever your need this machine provides the kind of technology and rigid accuracy not usually available at this price. If automation is not required then the FX3, with its 9kW wheel spindle, provides ample power to cover a wide range of applications. It offers the same software and machine quality that are found in all ANCA machines.

### FX<sup>5</sup> LINEAR

If you need automation and the versatility of more options, such as the MicroPlus, then the FX5 Linear will suit your needs. The FX5 features a new 12kW grinding spindle and also has an automatic 2-wheel changer for an increased range of wheels and tool types. Together with the automatic headstock clamping, the machine is "loader ready" and can provide unattended operation and the flexibility to handle small volumes. The ANCA-designed AR300 SCARA robot is ideal for mixed batches of tools.

### FX<sup>7</sup> LINEAR

For customers that require greater flexibility with more spindle power, increased automation capacity with a robot loader that also changes the wheel packs, the FX7 Linear is the machine that you are looking for. The FX7 Linear is the premium tool grinder in the FX range and provides exceptional value for money. It offers a wide range of options for those looking to increase productivity and accuracy.

### POWERED BY LINX®

Our LinX® linear motor technology for axis motion (X and Y axes), in conjunction with linear scales, achieves superior precision and performance.

Specially designed for a lifetime of operation in harsh grinding environments, the LinX® motors have a cylindrical magnetic field which means there is no additional down force on the rails or machine base.

With no temperature variations (meaning no need for a separate chiller unit), and being sealed to IP67, there is minimal wear and tear so that the machine accuracy remains over the lifetime of the machine. The LinX® linear motor has higher axis speed and acceleration, leading to reduced cycle times while maintaining a smoother axis motion.

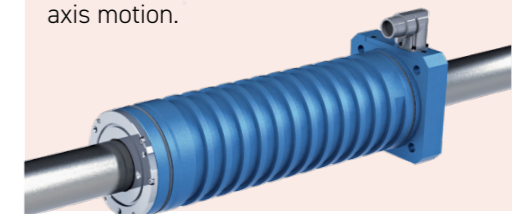

# ENHANCED ACCURACY

## UPGRADED TECHNOLOGY



### 1. HAND-HELD REMOTE PENDANT

Provides the operator with easier access to the machine during set-up.

### 2. CONTROL PANEL

Fitted with a 19" touch screen configured to machine options. Windows functionality with multi-touch and zoom.

### 3. AUTOMATION OPTIONS

ANCA AR300 robot loader for low-volume tool production or Robot loader for high-volume, also in combination with 6-station wheel changing capability for extended unattended operation.

### 4. LOADER ACCESS DOOR

The pallet slides out giving the operator quick and easy access to tools when using the Robot Loader.

### 5. TOOL / WHEEL MEASUREMENT OPTIONS

Automated for increased productivity. LaserUltra automatic tool measurement and compensation system. Wheel Probe for automatic wheel qualification. iView tool measurement.

### 6. COMPACT SIZE

A small compact footprint saving on floor space yet a large working envelope to satisfy high volume production.

### 7. RIGID DESIGN

Positioning the grinding wheel on the C-axis centreline reduces thermal effects, as does the more compact machine size.

### 8. LINEAR MOTORS (LINX®)

LinX® and linear scales improve precision and performance for superior tool accuracy and surface finish.

### 9. AMD5X DRIVE SYSTEM

Provides faster processing for increased productivity.

## FX3 Linear

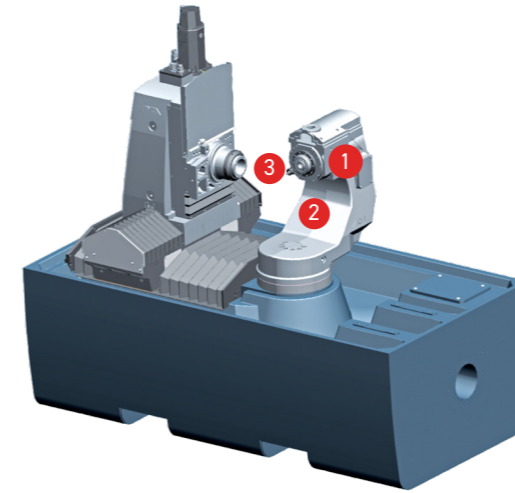

### 1. SPINDLE DESIGN

HSK40F taper provides increased rigidity and accuracy for improved tool surface finish results.

### 2. C-AXIS PIVOT POINT

As the grinding wheel is positioned on the centreline of the C-Axis motor, axis motion is reduced which is ideal for ballnose grinding ensuring accuracy is maintained.

### 3. EASY MACHINE ACCESS

Ergonomically designed for the operator. Easy access to the headstock workholding, wheel pack and spindle for quick set-up and job change-over.

### 4. WHEEL CHANGER

Options for 2 and 6 station wheel changer for maximum flexibility and productivity.

### 5. TOOL-SUPPORT

Options include a Steady Bed, Pop-Up Steady and MicroPlus systems to increase accuracy (Z-axis mounting).

## FX5 Linear

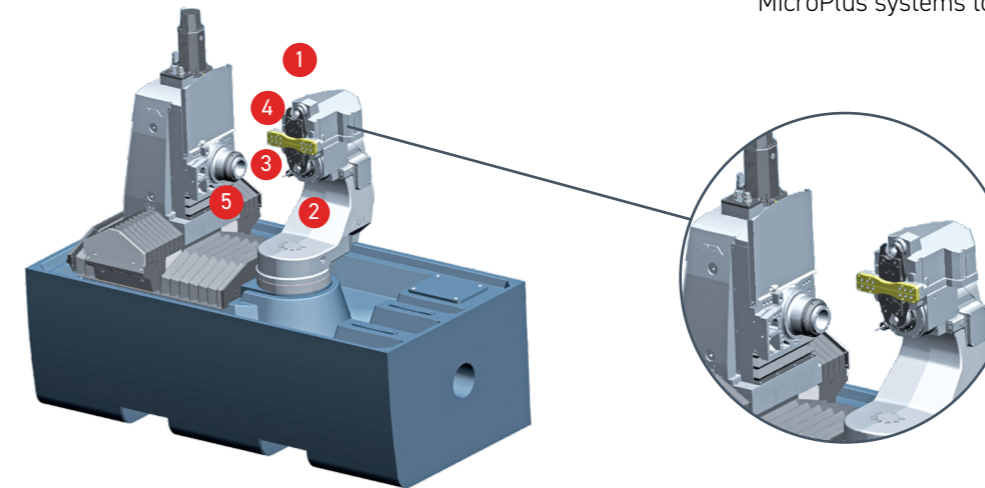

## FX7 Linear

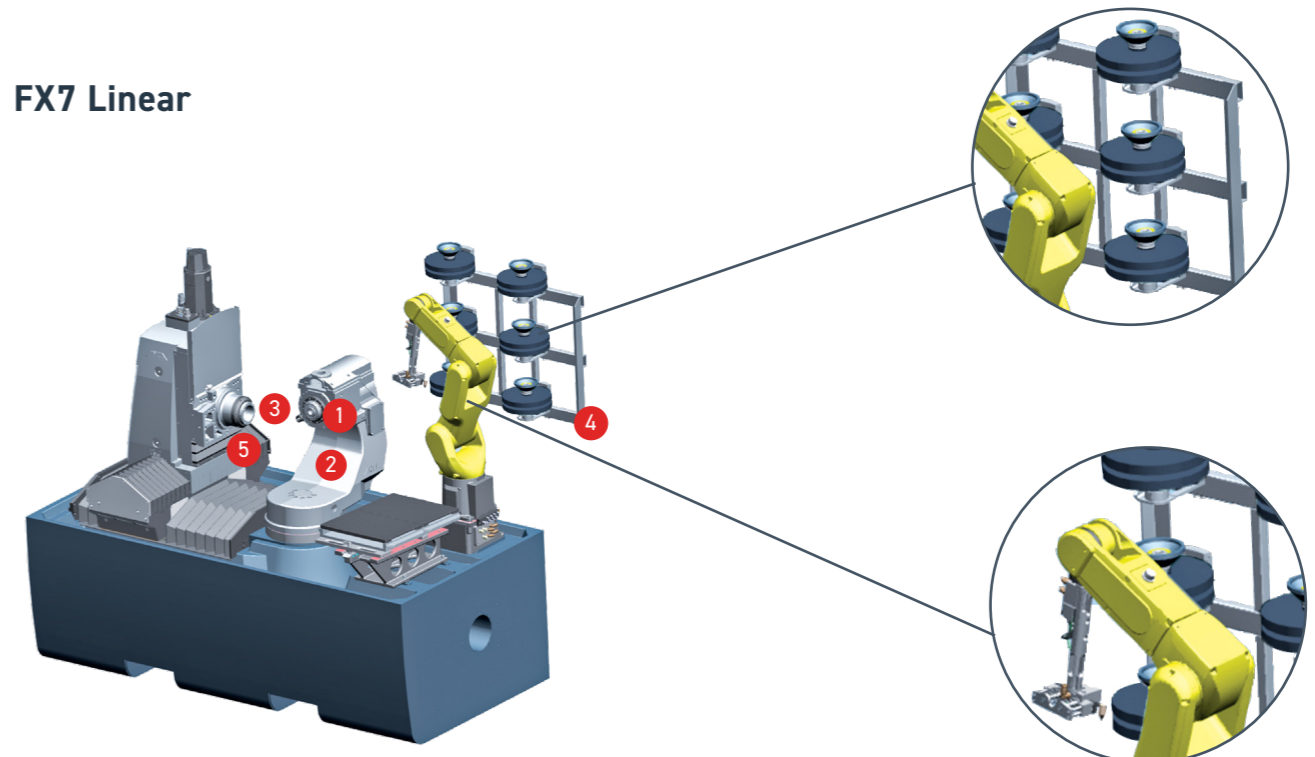

## OPERATING CONTROLS

### TOUCH SCREEN MONITOR



- ANCA designed full touch screen front panel (19")
- Latest touch screen technology
- Windows 10 functionality – multi touch, zoom, etc.
- Configured to machine – only machine 'options' are displayed on the screen
- Designed to withstand an industrial environment
- Configured so operator can quickly set up machine
- ANCA menu and other hard buttons are integrated into the soft panel or as soft touch keys

### REMOTE HANDHELD PENDANT



- Allows operator improved access for machine set-up
- Allows operator to remain comfortably standing at machine door during set-up instead of moving to screen or having to lean over
- Includes MPG (Manual Pulse Generator) so operator can safely test program step-by-step
- A feed-rate override control on the pendant allows the axis travel speed to be easily varied
- Also acts as a 'hold to run' to meet CE certification

## AUTOMATION

### AR300 ROBOT TOOL LOADER

*(FX5 option)*



ANCA's designed and built low cost tool loader is fully contained within the machine canopy. The AR300 loader has 3 axes and is easily set up and controlled via the touch screen and remote handheld pendant. It provides customers with an affordable automatic tool loading solution and is perfect for low-volume production runs.

- Operator access from front of machine
- Does not increase machine footprint
- One gripper set for the entire diameter range
- Ideal for loading tools  $\varnothing 2 - 20$  mm ( $1/18'' - 3/4''$ )
- Tool length range 30 - 150 mm ( $1\frac{1}{2}'' - 6''$ )
- Double gripper, tool change for load/unload
- Loading time of 15 seconds
- The pallet capacity ranges from 380 tools with  $\varnothing 2$  mm ( $1/8''$ ) shank, 200 tools with  $\varnothing 6$  mm ( $1/4''$ ) shank and 33 tools for  $\varnothing 20$  mm ( $3/4''$ ) shank

### FANUC ROBOT LOADER

*(FX5 option/FX7 standard)*



The Fanuc Robot Loader is a versatile automation solution that is located completely within the FX Linear machine. It provides automatic tool loading, enabling extended periods of unmanned operation, for maximised productivity.

- Can be used to auto-load up to 6 wheel packs & their coolant manifolds
- Operator access from front of machine
- Does not increase machine footprint
- One gripper set for the entire diameter range
- Ideal for loading tools  $\varnothing 2 - 20$  mm ( $1/16'' - 3/4''$ )
- Tool length range 30 - 250 mm ( $1\frac{1}{4}'' - 10''$ )
- Double gripper, tool change for load/unload
- Loading time of 9 seconds
- The pallet capacity ranges from 840 tools with  $\varnothing 2$  mm ( $1/8''$ ) shank, 520 tools with  $\varnothing 6$  mm ( $1/4''$ ) shank and 96 tools for  $\varnothing 20$  mm ( $3/4''$ ) shank

## ACCESSORIES

### MICROPLUS

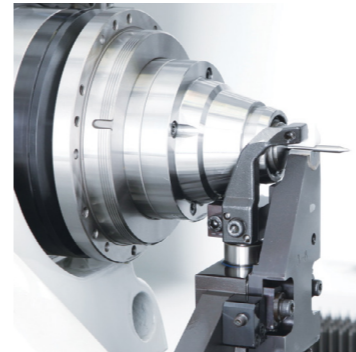

MicroPlus provides less than 3 micron tool runout. It is ANCA's #1 high accuracy work holding and tool support system. The MicroPlus system consists of the Flexi-Chuck assembly for workholding, and the Overhead Top Clamp Assembly (OTC) for tool support. The Flexi-Chuck clamps and rotates the tool. The patented design allows the tool and the internal components to move independently of each other, minimising any misalignment.

The OTC consists of a V-block that supports the tool and a rigid overhead metal finger that holds the tool in place. The OTC provides alignment accuracy for the tool.

- Less than 3 micron (0.0001") runout
- Available for FX5 Linear and FX7 Linear tool grinders
- Elimination of radial and axial runout

### LASERULTRA



The LaserUltra system provides accurate and repeatable measurement of tools inside the machine. The LaserUltra can automatically measure OD, run-out, EOT, ball nose and corner radius profile tools. An air blast unit on the laser ensures that coolant or contaminants do not interfere with the measurement process.

- Faster set-up times
- Less scrap
- No need to remove the tool from the machine
- Increased efficiency
- Laser OD SPC (Statistical Process Control) cycle also available
- Laser is permanently mounted inside the machine

## PREMIERPLUS COLLET ADAPTORS

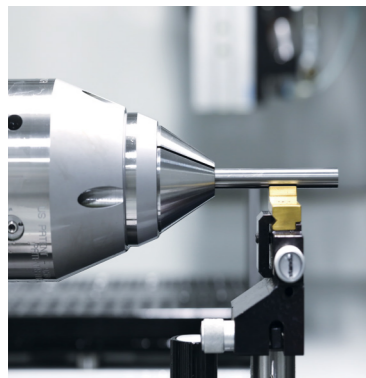

ANCA's Premierplus Collet Adaptors provides operators with a premium workholding range. The Premierplus Collet Adaptors use a new totally internal clamping mechanism. The spring pack in the adaptor provides the tool clamping force and prevents possible runout that was previously added if misalignment occurred between the drawbar and the collet. PremierPlus Collet Adaptors offer users the ability to make radial adjustments to the collet to obtain low run out on tools.

- Reduces tool runout for improved tool quality
- Available in W20, W25 and B32/45 versions
- PCA (Precision Collet Adaptor) versions also available
- Available for the FX5 Linear and FX7 Linear tool grinders

## WHEEL PROBE



The auto wheel pack qualification probe is used to accurately measure grinding wheels inside the machine. The Wheel Probe uses a Renishaw probe to qualify the wheel pack. It is possible to measure the front surface location, back surface location, wheel diameter and toroid radius of a grinding wheel. It eliminates the need for operator intervention which ensures consistent measurement results.

- Automatically measures a wide variety of wheel shapes
- Eliminates the need to manually qualify the wheel pack
- Eliminates the need to remove the wheel pack from the grinder
- Increases machine productivity
- Reduces first tool rejections

## IVIEW

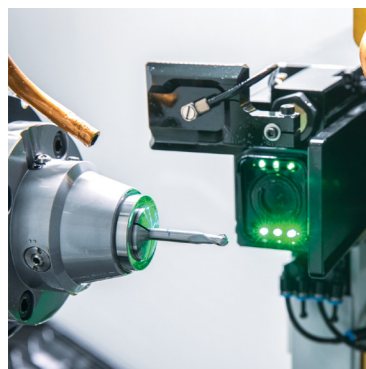

iView is a measuring system that is able to measure the ground tool while it is still in the work-holding on the machine. The image of the ground tool as taken by the iView camera is compared with an ideal overlay shape generated by the software. The tool size can then be compensated automatically based on the overlay.

- Eliminates the need to remove a tool from the grinder in order to check the dimensions
- Reduces errors caused by relocating tool and manually compensating
- 90x – 360x range of tool magnification
- Provides measuring accuracy to 2 microns
- iView is permanently mounted inside machine

## 6-WHEEL CHANGER



Used in conjunction with the Robot Loader. 6 wheel packs and coolant manifolds are loaded together, stored on a frame next to the robot. A docking station allows the wheel pack to be located close to the wheel spindle for fast wheel change cycle times. The wheel changer is totally contained within the FX7 canopy.

- Utilises robot for maximised productivity
- Maximum of 6 wheel packs
- Changes wheels plus coolant manifolds
- Cycle time <12 seconds
- Maximum wheel diameter  $\varnothing$ 203 mm (8")

## SOFTWARE

### TOOLROOM



ANCA's ToolRoom software suite caters for a wide range of tool types and applications with an easy-to-use interface to input tool geometry parameters. ToolRoom ensures that the FX Linear machines will efficiently handle any regrinding or manufacture challenge.

The machine operator is able to easily and quickly set up or modify tool programs, depending upon the required tool type. For more proficient users, advanced software pages exist to access complex tool designs and operations. ToolRoom supports the grinding of drills, end mills, profile tools, burrs, routers and many other special applications.

### CIM3D



CIMulator3D simulates the programmed tool path exactly as it would be ground on the machine. New tool programs can be verified for size, shape, machine clearance and even cycle time estimates. CIMulator3D maintains continuous work flow through the machine by reducing development time and trial grinding.

ANCA was the first to introduce true 3D simulation technology for CNC tool and cutter grinding. CIM3D delivers advanced tool simulation quality and an enhanced user-friendly interface for high performance and increased efficiency.

### TOOLDRAFT

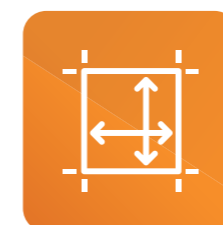

ToolDraft is used for creating 2D cutting tool drawings from a simulated tool or direct from ToolRoom. This is built on the foundation of CIM3D engine projecting a 3D model into accurate 2D projection views. This will help customers to create drawings of cutting tools manufactured on ANCA machines without relying on third party software.

- Dimension all tool features with tolerances and surface finish requirements
- Annotate drawing with text, images, and drafting symbols from the drafting symbols library
- Load and save customer defined drawing templates with defined text, line and colour styles
- Export drawing as PDF or DXF with ability to print drawing

### MANAGEMENT SUITE



Management Suite provides customers with the ability to manage their tool production, tool files and wheel files. This standalone software comes with three main features:

- REDAX monitors machine production 24/7 in real-time and delivers up-to-date information, greatly enhancing the visibility and control of the tool manufacturing operation. This system will enable customers to improve the productivity of their machines by reducing machine downtime, analysing tool production, and past production history.
- Wheel management is a server-based wheel library which provides means to easily share wheel packs and qualification data between machines.
- Tool management is a server-based application which makes it easy to transfer grinding files between simulators and machines. This also maintains version control and history of all tool files, and has read/write user permissions for better control of tool files.



### ARE YOU A MEMBER OF THE ANCA CLUB?

Get exclusive access to valuable training information, software releases and updates. For ANCA Customers only, access is arranged by request via [ancaclubenquiries@anca.com](mailto:ancaclubenquiries@anca.com)



### DO YOU RECEIVE OUR MONTHLY E-SHARP NEWSLETTER?

Available in nine languages, every month we share customer success stories, latest products, services, and tips on how to get the most from your grinding investments.



### TOOL TIP TUESDAY

Follow #ANCAToolTipTuesday for weekly tips on getting the most out of your ANCA software.



### CONNECT WITH US AND

### STAY AHEAD

@ANCACNCmachines  
[www.anca.com](http://www.anca.com)



### ANCA ACADEMY

The ANCA Academy show covers technical topics through educational videos on new applications and features.